

ICOM

INSTRUCTION MANUAL

---

VHF REPEATER  
**IC-RP1620**  
50 W version

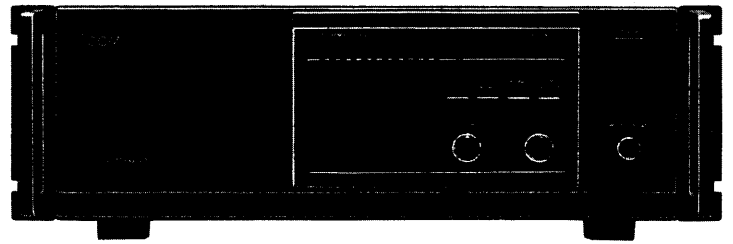

---

Icom Inc.

---

## IMPORTANT

---

**READ THIS INSTRUCTION MANUAL** carefully and completely before using the IC-RP1620.

**SAVE THIS INSTRUCTION MANUAL.**

This instruction manual contains important safety and installation instructions.

---

## FOREWORD

---

Thank you for purchasing the **IC-RP1620 VHF REPEATER**. This repeater is designed to meet professional communication requirements.

If you have any questions, contact your nearest authorized Icom Dealer or Service Center.

---

## PRECAUTIONS

---

**⚠ DISCONNECT** the AC power cable from the repeater, and wait for a few minute before performing AC fuse replacement or any internal work.

**⚠ NEVER** apply AC voltage that exceeds the suggested voltage for each version. This could cause a fire or ruin the repeater.

**⚠ NEVER** use not-rated fuses. Not-rated fuses could cause a fire or ruin the repeater.

**⚠ NEVER** touch the antenna connector, ground terminal or antenna while transmitting.

**⚠ NEVER** touch internal parts while transmitting. Stop transmitting when internal adjustments are performed.

**⚠ NEVER** let metal, wire or other objects touch any internal part. This could cause an electric shock.

**⚠ NEVER** expose the repeater to rain, snow or any liquids.

**⚠** If a lithium backup battery is incorrectly replaced, an explosion may occur. The backup battery should be replaced by an authorized Icom Dealer or Service Center.

**⚠ GROUND** the repeater through the [GND] terminal to prevent electric shocks, TVI, BCI and other problems.

---

## EXPLICIT DEFINITIONS

---

Word	Definition
<b>⚠ WARNING</b>	Personal injury, fire hazard or electric shock may occur.
<b>CAUTION</b>	Equipment damage may occur.
<b>NOTE</b>	If disregarded, inconvenience only. No personal injury, fire hazard or electric shock will occur.

---

## FEATURES

---

- Stable 50 W output power
- Remote control capability
- Meets European safety requirements
- Easy-to-program timers
- Great even during power failures

**⚠ NEVER** connect the [GND] terminal to a gas or electrical pipe, since the connection could cause an explosion or electric shock.

**NEVER** allow children to touch the repeater.

**NEVER** apply DC voltage that exceeds 16 V. This could ruin the repeater. **NEVER** connect 24 V battery.

**AVOID** using the repeater in areas where the temperature is below  $-10^{\circ}\text{C}$  or over  $+60^{\circ}\text{C}$ .

**AVOID** placing the repeater against walls or putting anything on the top of the repeater. This could obstruct heat dissipation.

**AVOID** using the repeater in excessively dusty environments.

**AVOID** placing the repeater in direct sunlight.

**AVOID** the use of strong cleaning agents such as benzene or alcohol.

**BE CAREFUL!** The heatsink becomes hot when operating the repeater.

Protect your repeater from lightning using a lightning arrestor.

## TABLE OF CONTENTS

<b>1 PANEL DESCRIPTION</b> .....	<b>1-2</b>	■CTCSS encoder frequency.....	<b>8</b>
■Front panel.....	1	■CTCSS frequency table.....	8
■Rear panel .....	2		
<b>2 INSTALLATIONS</b> .....	<b>3-5</b>	<b>5 ADVANCED PRESETTINGS AND</b>	<b>OPERATION</b> .....
■Rear panel connections.....	3	■Automatic ID function.....	9-14
■Mounting handles.....	3	■ID speed.....	9
■Location.....	4	■ID speed.....	9
■Antenna .....	4	■Manual ID function.....	9
■Coaxial cable .....	4	■Hang-up timer.....	9
■Duplexer .....	4	■Time-out timer.....	9
■PL-259 connector .....	4	■Repeater-stopping timer.....	10
■Grounding.....	4	■Time-out signal.....	10
■AC power connection.....	5	■ID transmitting timing.....	10
■DC power connection.....	5	■ID call sign setting .....	13
■Microphone connector.....	5	■Remote control function.....	13
■Accessory socket.....	5		
<b>3 BASIC OPERATION</b> .....	<b>6</b>	<b>6 MAINTENANCE</b> .....	<b>15-16</b>
■Initial settings.....	6	■Disassembly .....	15
■Normal operation.....	6	■RAM backup battery .....	15
■Power failure operation.....	6	■Cleaning .....	15
■Convenient functions.....	6	■Fuse replacement .....	15
		■CPU resetting.....	15
		■Troubleshooting.....	16
<b>4 BASIC PRESETTINGS</b> .....	<b>7-8</b>	<b>7 INSIDE VIEWS</b> .....	<b>17-19</b>
■Dip switches.....	7	■Top view .....	17
■PLL reference frequency.....	7	■Bottom view.....	18
■Frequency settings.....	7	■LOGIC-A unit .....	19
■Frequency setting examples.....	7		
■CTCSS decoder frequency.....	8	<b>8 SPECIFICATIONS</b> .....	<b>20</b>

## UNPACKING

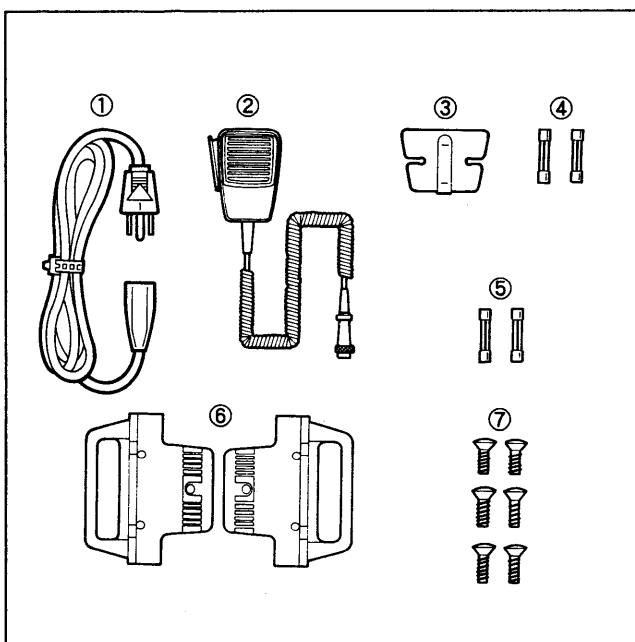

Accessories included with the IC-RP1620	Qty.
① AC power cable.....	1
- U.S.A. version OPC-034	
- Europe version OPC-419	
② Hand microphone (HM-4).....	1
③ Microphone hanger.....	1
④ Spare fuses for AC line (5.2 <sup>φ</sup> × 20 mm).....	2
- U.S.A. version 5 A time-lag type	
- Europe version 2.5 A time-lag type	
⑤ Spare fuses for DC line (6.4 <sup>φ</sup> × 30 mm, 20 A).....	2
⑥ Rack mounting handles (MB-19).....	2
⑦ Screws for rack mounting handles.....	6

The following parts are required for installation, but are not supplied with the IC-RP1620.

- 50 Ω coaxial cable (p. 4)
- PL-259 connectors (p. 4)
- Transmit and receive antennas or 1 antenna with duplexer (p. 4)

# 1 PANEL DESCRIPTION

## ■ Front panel

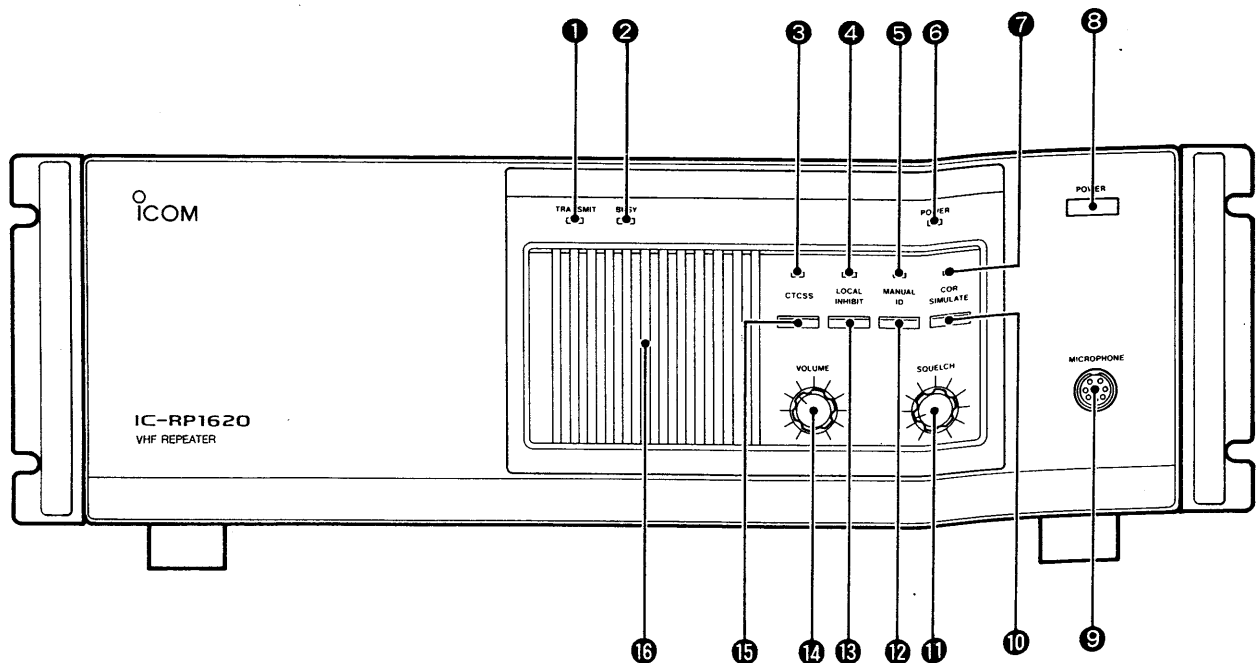

- ① TRANSMIT INDICATOR [TRANSMIT]**  
Lights up in red when transmitting.
- ② BUSY INDICATOR [BUSY]** (p. 6)  
Lights up in green when receiving with the squelch open.
- ③ CTCSS INDICATOR [CTCSS]** (p. 6)  
Lights up in green when the CTCSS function is turned ON.
- ④ LOCAL INHIBIT INDICATOR [LOCAL INHIBIT]**  
(p. 6)  
Lights up in yellow when the repeater function is inhibited.
- ⑤ ID INDICATOR** (p. 9)  
Lights up in red while the ID call sign is transmitted.
- ⑥ POWER INDICATOR [POWER]** (p. 6)  
Lights up in green during AC operation and in red during DC operation.
- ⑦ COR SIMULATE INDICATOR [COR SIMULATE]**  
(p. 6)  
Lights up in yellow when the COR simulate function is activated.
- ⑧ POWER SWITCH [POWER]** (p. 6)  
Turns the power ON and OFF.
- ⑨ MICROPHONE CONNECTOR [MICROPHONE]**  
(p. 5)  
Connects the supplied hand microphone.
- ⑩ COR SIMULATE SWITCH [COR SIMULATE]**  
(p. 6)  
Activates continuous transmission for checking repeater operation.
- ⑪ SQUELCH CONTROL [SQUELCH]** (p. 6)  
Adjusts the weakest receive signal strength to be repeated.
- ⑫ MANUAL ID SWITCH [MANUAL ID]** (p. 9)  
Transmits an ID call sign manually.
- ⑬ LOCAL INHIBIT SWITCH [LOCAL INHIBIT]**  
(p. 6)  
Inhibits the repeater function. The repeater operates as a semi duplex transceiver.
- ⑭ VOLUME CONTROL [VOLUME]** (p. 6)  
Adjusts the audio output level from the speaker.
- ⑮ CTCSS SWITCH [CTCSS]** (p. 6)  
Turns the CTCSS function ON and OFF.
- ⑯ SPEAKER**  
Monitors the received signal.

## ■ Rear panel

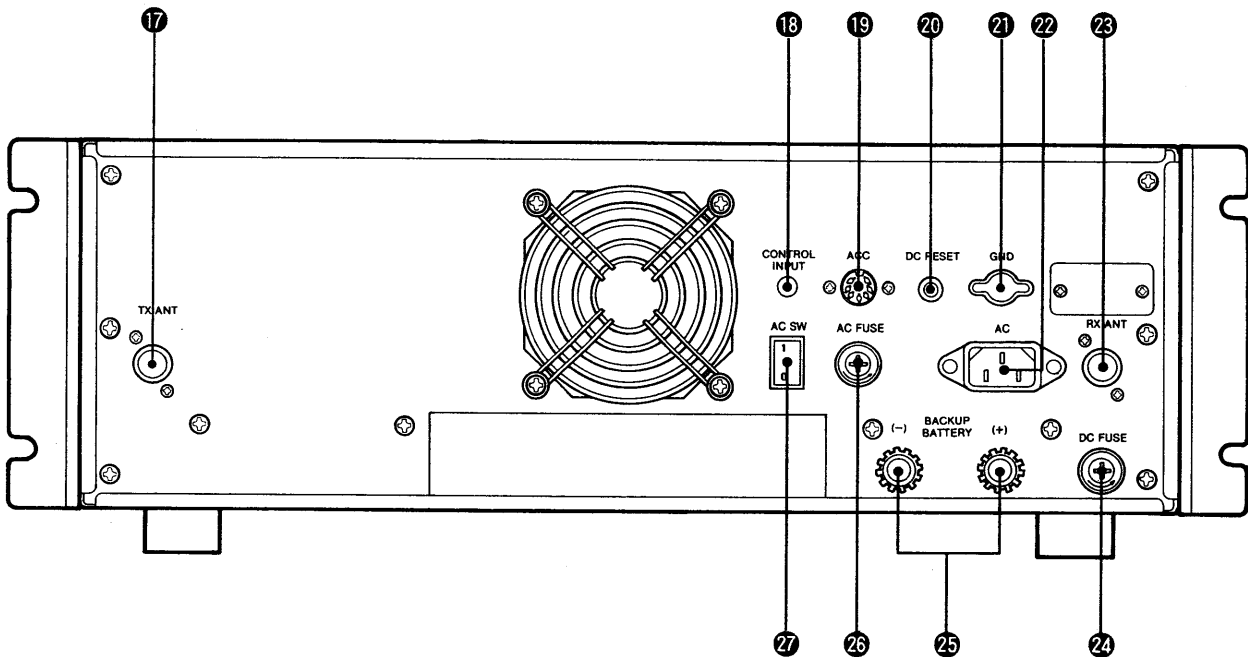

**17 TRANSMIT ANTENNA CONNECTOR [TX ANT]** (p. 4)  
Outputs the transmitter output power to a duplexer.

**18 CONTROL SIGNAL INPUT JACK [CONTROL INPUT]** (p. 13)  
If required, connect an external receiver that receives DTMF codes on another frequency for remote control.

**19 ACCESSORY SOCKET [ACC]** (p. 5)  
Inputs and outputs signals for external equipment.

**20 DC POWER RESET SWITCH [DC RESET]** (p. 6)  
Cancels the discharging limiter.

**21 GROUND TERMINAL [GND]** (p. 4)  
Ground the repeater through this terminal to prevent an electric shock, TVI, BCI and other problems.

**22 AC POWER SOCKET [AC]** (p. 5)  
Connects the supplied AC power cable to an AC outlet.  
– U.S.A. version : 117 V AC  $\pm 10\%$ , 50/60 Hz  
– Europe version : 230 V AC  $\pm 10\%$ , 50/60 Hz

**⚠ WARNING: NEVER** apply AC voltage that exceeds the suggested voltage for each version. This could cause a fire or ruin the repeater.

**23 RECEIVE ANTENNA CONNECTOR [RX ANT]** (p. 4)  
Inputs receive signals from a duplexer.

**24 DC FUSE HOLDER [DC FUSE]** (p. 15)  
Holds a 20 A fuse for the internal DC power supply.

**25 BACKUP BATTERY TERMINALS [BACKUP BATTERY]** (p. 5)  
– Connect a 12 V storage battery in case of AC power failure. During AC power operation, the connected battery is charged. Charging current from the repeater is approx. 100 mA.  
– Connect 13.8 V  $\pm 15\%$ , more than 15 A DC power supply for DC power operation.

**⚠ CAUTION: DO NOT** connect a DC power supply during AC power operation.

**26 AC FUSE HOLDER [AC FUSE]** (p. 15)  
Holds a fuse for the internal AC power supply.  
– U.S.A. version : 5 A time-lag type  
– Europe version : 2.5 A time-lag type

**⚠ WARNING: NEVER** use a non-rated fuse. This could cause a fire.

**27 AC MAIN SWITCH [AC SW]** (p. 6)  
Turns AC line ON and OFF.  
– “I” position : For AC operation  
– “O” position : For DC operation

# 2 INSTALLATIONS

## Rear panel connections

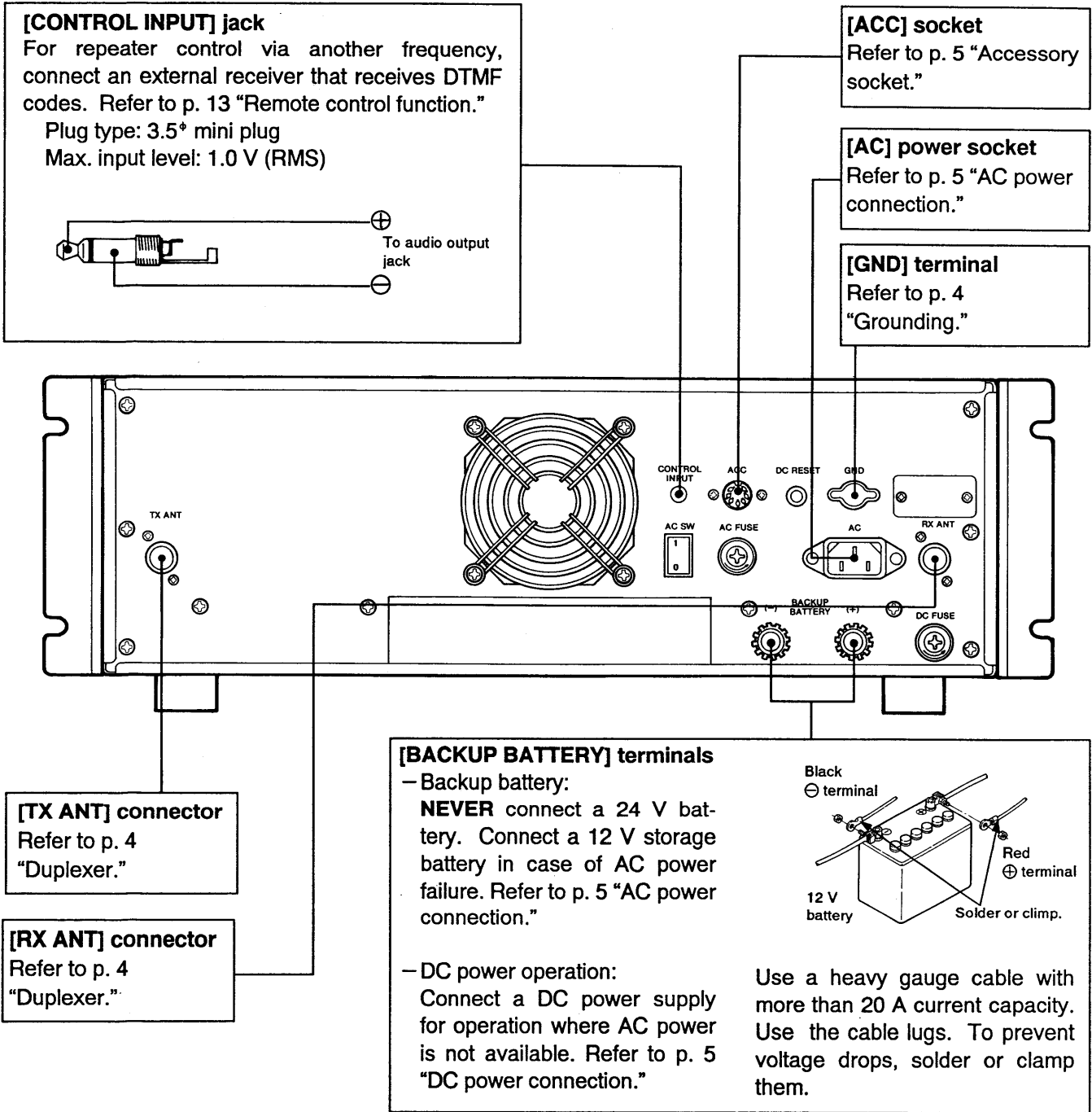

## Mounting handles

To install the repeater into an EIA standard 19-inch rack, attach supplied mounting handles.

- 1) Remove the 2 screws from each side of the front panel.
- 2) Attach the mounting handles using the supplied screws.

## Location

Select a location for the repeater that allows adequate air circulation, free from extreme heat, cold or vibrations, and away from TV sets, radios, and other electro-magnetic sources.

Allow sufficient access between the repeater and walls for maintenance.

Use supplied mounting handles to install into an EIA standard 19-inch rack. Refer to p. 3 "Mounting handles."

## Antenna

**CAUTION:** Protect your repeater from lightning using a lightning arrestor.

Select a well-matched 50 Ω antenna. An omnidirectional antenna is recommended for ordinary conditions. VSWR should be less than 1.5:1. Use heavy-duty stainless steel mounting hardware to protect the antenna from bad weather.

## Coaxial cable

Use 50 Ω coaxial cables as feed lines. The coaxial cables should be as short in length and as thick as possible.

## Duplexer

A duplexer is separately required when only one antenna is used for both transmitting and receiving. Select a duplexer according to transmit and receive frequencies. Ask your Icom Dealer for details.

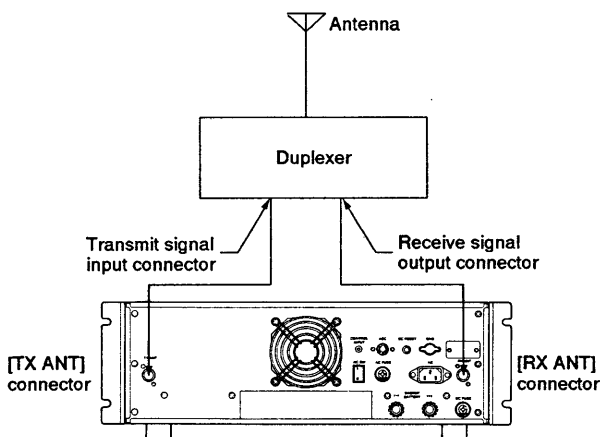

## PL-259 connector

1) Slide the coupling ring down. Strip the cable jacket and soft solder.

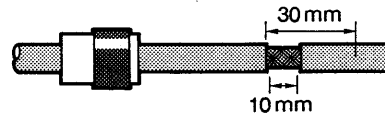

2) Strip the cable. Soft solder the center conductor.

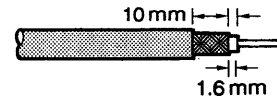

3) Slide the connector body on and solder it.

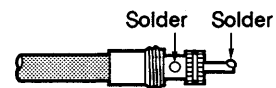

4) Screw the coupling ring onto the connector body.

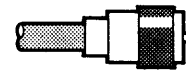

10 mm ≈ 3/8 inches

## Grounding

To prevent an electric shock, TVI, BCI and other problems, ground the repeater through the [GND] terminal.

For the best results, connect a heavy gauge cable to a long earth-sunk copper rod. Make the distance between the [GND] terminal and copper rod as short as possible.

**WARNING: NEVER** connect the [GND] terminal to a gas or electric pipe, since the connection could cause an explosion or electric shock.

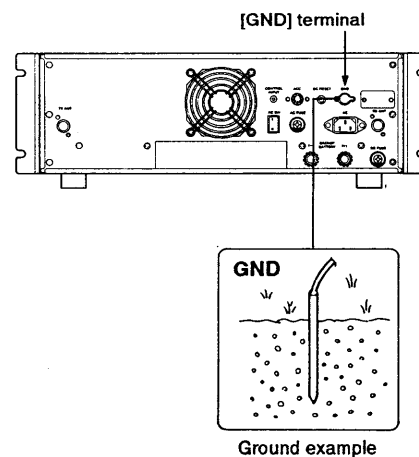

### ■ AC power connection

**⚠ WARNING: NEVER** apply AC voltage that exceeds the suggested voltage for each version. Verify AC voltage from the AC outlet voltage:

- U.S.A. version : 117 V AC ±10%, 50/60 Hz
- Europe version : 230 V AC ±10%, 50/60 Hz

- 1) Turn OFF the [AC SW] switch on the rear panel and the [POWER] switch on the front panel.
  - [AC SW] : "O" position
  - [POWER] : OUT position

- 2) Connect the supplied AC power cable to the repeater. Connect the AC power cable to an AC outlet.

**NOTE:** Use an AC outlet that can supply more than 240 VA power. **AVOID** the use of multi-plug adapters unless absolutely necessary.

- 3) If required, connect the DC power cable to the [BACKUP BATTERY] terminals. Connect the DC power cable to a 12 V storage battery.

- The 12 V storage battery ensures operation during AC power failures.

#### Backup battery cautions and notes

**CAUTION: NEVER** connect a 24 V battery.

**DO NOT** place the battery within 5 m; 16.4 feet of the repeater supply.

**NOTE:** Charge the storage battery in advance. During AC power operation, the connected battery is charged with approx. 100 mA of current drain.

### ■ DC power connection

For operation where AC power is not available, the repeater accepts a 13.8 V ±15% DC power supply.

Connect a DC power source to the [BACKUP BATTERY] terminals as described in "Battery connection."

**CAUTION: NEVER** apply DC voltage that exceeds 16 V. Use a DC power source and DC power cable with more than 20 A current capacity.

### ■ Microphone connector

Connect the supplied HM-4 HAND MICROPHONE to the [MICROPHONE] connector.

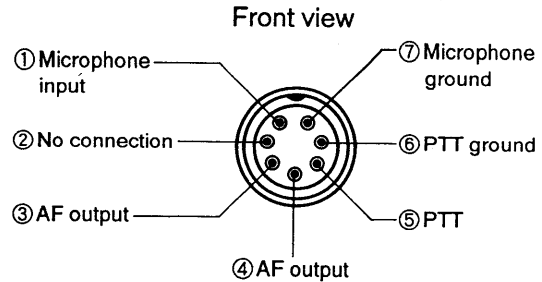

### ■ Accessory socket

If required, connect external equipment to the [ACC] socket.

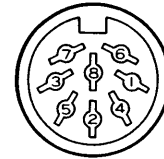

Front view

Pin No.	Pin name	Description	Specifications
1	NC	No connection.	—
2	GND	Connects to ground.	—
3	SEND	<ul style="list-style-type: none"> <li>• Transmits while grounded.</li> <li>• Connected to ground while transmitting.</li> </ul>	Ground level: - 0.5 to + 0.8 V Input current: Less than 20 mA
4	MOD	External modulator input. Connects to a modulator.	Impedance: 10 kΩ Level: Approx. 500 mV (RMS)
5	AF	Fixed AF output regardless of [VOLUME].	Impedance: 1.5 kΩ Output level: Max. 85 mV (RMS)
6	SQLS	Squelch output. Grounded when squelch opens.	Squelch open: Less than 0.3 V 5 mA Squelch closed: More than 6.0 V 100 μA
7	13.8V	13.8 V DC output.	Output current: Max. 1 A
8	NC	No connection.	—

**CAUTION: NEVER** connect pin 7 to ground, since the internal regulator circuit may be damaged or the DC line fuse may blow.



## Initial settings

Before applying power for the first time, perform the following internal settings:

- PLL reference frequency (p. 7)
- Transmit/receive frequencies (p. 7)
- CTCSS encoder/decoder frequencies for closed repeater operation (p. 8)

If required, perform the following internal settings:

- Automatic ID function (p. 9)
- ID speed (p. 9)
- Hang-up timer (p. 9)
- Time-out timer (p. 9)
- Repeater-stopping timer (p. 10)
- ID call sign settings (p. 10)

Select switches and controls on the front panel as shown below:

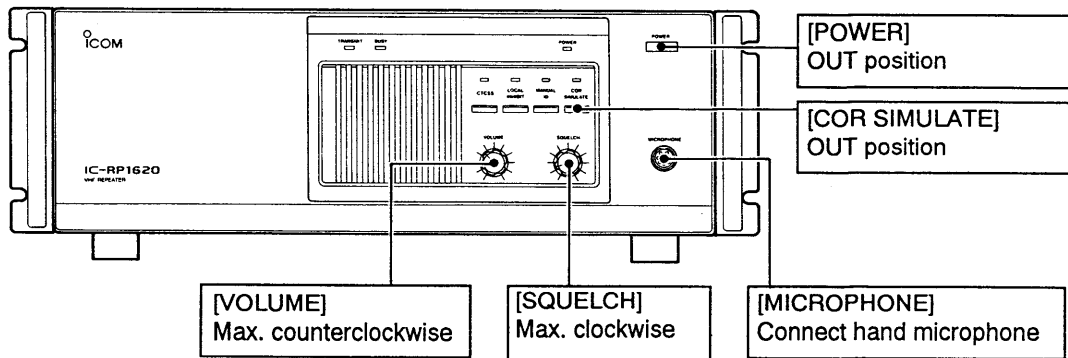

## Normal operation

- 1) For AC operation, turn the [AC SW] switch on the rear panel to the "I" position.
  - The [POWER] indicator lights up in green.
- 2) Push the [POWER] switch IN to turn power ON.
  - For DC operation, the [POWER] indicator lights up in red.
- 3) Push the [CTCSS] switch to select either closed repeater mode or open repeater mode.

Mode	[CTCSS] indicator	Repeater operation
Closed repeater	Lights up in green.	Repeats a received signal with a specified CTCSS frequency only.
Open repeater	Goes out.	Repeats any received signal.

- 4) Rotate the [VOLUME] control clockwise to adjust the desired audio output level.
- 5) Rotate the [SQUELCH] control counterclockwise to adjust to the weakest receive signal strength that you wish to repeat.
  - The [BUSY] indicator lights up in green while squelch opens.

## Power failure operation

When AC power is interrupted, the connected backup battery is automatically selected.

If the repeater stops operation during DC operation, disconnect the battery. Recharge the battery, then push the [DC RESET] switch to continue operation.

## Convenient functions

### Hand microphone

To transmit your voice from the repeater, push the PTT switch on the connected hand microphone.

- Be careful not to overlap received audio signals.

### Local inhibit function

To operate the repeater as a transceiver, activate the local inhibit function. Push the [LOCAL INHIBIT] switch to activate or cancel this function.

- The [LOCAL INHIBIT] indicator lights up in yellow when this function is activated.

### COR simulate function

To transmit continuously for the repeater setting confirmation, activate the COR simulate function. Push the [COR SIMULATE] switch to the IN position.

- The [COR SIMULATE] indicator lights up in yellow when this function is activated.

# 4 BASIC PRESETTINGS

## ■ Dip switches

Refer to p. 15 "Disassembly" and remove the bottom cover. For the dip switch locations, refer to p. 19 "LOGIC-A unit."

## ■ PLL reference frequency

According to the tuning step, select either 5 kHz or 12.5 kHz reference frequency via the PLL reference frequency switch S4-1.

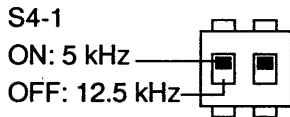

## ■ Frequency settings

- 1) Calculate the PLL N-data as in the "Frequency setting examples" below.
- 2) Set the PLL N-data.
  - Receive frequency switches: S1-1 to S1-10 and S2-1 to S2-7
  - Transmit frequency switches: S9-1 to S9-10 and S10-1 to S10-7
- 3) After replacing the bottom cover, turn ON the power and confirm selected frequency.

## ■ Frequency setting examples

### Receive frequency setting example

Receive frequency : 157.435 MHz  
1st IF frequency : 21.800 MHz  
PLL reference frequency : 0.005 MHz (5 kHz)

$$\begin{aligned} \text{N-data} &= \frac{\text{Receive frequency} - \text{1st IF frequency}}{\text{PLL reference frequency}} \\ &= \frac{157.435 - 21.800}{0.005} \\ &= 27127 \end{aligned}$$

Set the receive frequency switches S1-1 to S1-10 and S2-1 to S2-7 to the values equivalent to the obtained N-data.

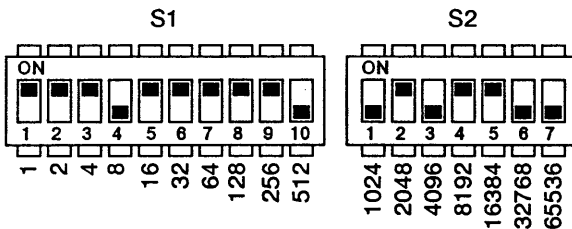

Dip switches	N-data value
S2-5	16384
S2-4	8192
S2-2	2048
S1-9	256
S1-8	128
S1-7	64
S1-6	32
S1-5	16
S1-3	4
S1-2	2
S1-1	1
<b>Total</b>	<b>27127</b>

### Transmit frequency setting example

Transmit frequency : 167.15 MHz  
PLL reference frequency : 0.0125 MHz (12.5 kHz)

$$\begin{aligned} \text{N-data} &= \frac{\text{Transmit frequency}}{\text{PLL reference frequency}} \\ &= \frac{167.15}{0.0125} \\ &= 13372 \end{aligned}$$

Set the transmit frequency switches S9-1 to S9-10 and S10-1 to S10-7 to the values equivalent to the obtained N-data.

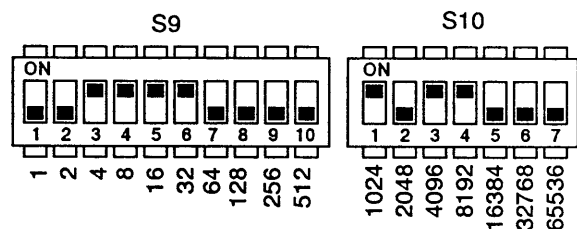

Dip switches	N-data value
S10-4	8192
S10-3	4096
S10-1	1024
S9-6	32
S9-5	16
S9-4	8
S9-3	4
<b>Total</b>	<b>13372</b>

### ■ CTCSS decoder frequency

For closed repeater operation, set a CTCSS decoder frequency.

According to the following table, set CTCSS decoder frequency switches S3-1 to S3-6.

Initial setting before shipping is 88.5 Hz.

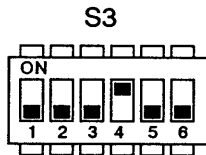

### ■ CTCSS encoder frequency

If required, the repeater can transmit a CTCSS frequency.

According to the following table, set CTCSS encoder frequency switches S11-1 to S11-6. After frequency setting, turn CTCSS encoder switch S5 ON.

Initial setting before shipping is 88.5 Hz.

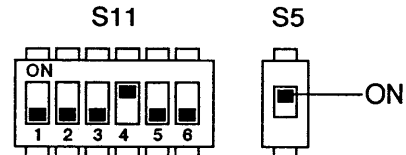

### ■ CTCSS frequency table

The following table is for CTCSS decoder and encoder frequency settings.

Tone number	Frequency [Hz]	Dip switches						Tone number	Frequency [Hz]	Dip switches					
		1	2	3	4	5	6			1	2	3	4	5	6
01	67.0	ON	—	—	—	—	—	20	131.8	—	—	ON	—	ON	—
02	71.9	—	ON	—	—	—	—	21	136.5	ON	—	ON	—	ON	—
03	74.4	ON	ON	—	—	—	—	22	141.3	—	ON	ON	—	ON	—
04	77.0	—	—	ON	—	—	—	23	146.2	ON	ON	ON	—	ON	—
05	79.7	ON	—	ON	—	—	—	24	151.4	—	—	—	ON	ON	—
06	82.5	—	ON	ON	—	—	—	25	156.7	ON	—	—	ON	ON	—
07	85.4	ON	ON	ON	—	—	—	26	162.2	—	ON	—	ON	ON	—
08	88.5	—	—	—	ON	—	—	27	167.9	ON	ON	—	ON	ON	—
09	91.5	ON	—	—	ON	—	—	28	173.8	—	—	ON	ON	ON	—
10	94.8	—	ON	—	ON	—	—	29	179.9	ON	—	ON	ON	ON	—
11	97.4*	ON	ON	—	ON	—	—	30	186.2	—	ON	ON	ON	ON	—
12	100.0	—	—	ON	ON	—	—	31	192.8	ON	ON	ON	ON	ON	—
13	103.5	ON	—	ON	ON	—	—	32	203.5	—	—	—	—	—	ON
14	107.2	—	ON	ON	ON	—	—	33	210.7	ON	—	—	—	—	ON
15	110.9	ON	ON	ON	ON	—	—	34	218.1	—	ON	—	—	—	ON
16	114.8	—	—	—	—	ON	—	35	225.7	ON	ON	—	—	—	ON
17	118.8	ON	—	—	—	ON	—	36	233.6	—	—	ON	—	—	ON
18	123.0	—	ON	—	—	ON	—	37	241.8	ON	—	ON	—	—	ON
19	127.3	ON	ON	—	—	ON	—	38	250.3	—	ON	ON	—	—	ON

— : OFF

\*For the CTCSS decoder, 97.4 Hz cannot be programmed.

If required, CTCSS encoder frequency and decoder frequency can be programmed independently.

The tone numbers are used for CTCSS frequency setting using the remote control function. Refer to p. 13 "Remote control function" and p. 14 "Command and data."

### Automatic ID function

The repeater automatically transmits the call sign of the repeater in Morse code.

ID transmission pattern is selectable via the ID transmit pattern switches S12-1 and S12-2. Refer to pgs. 10 – 12 "ID transmitting timing."

	ID transmission pattern			
	Type A	Type B	Type C	Not used
S12-1	OFF	ON	ON	OFF
S12-2	ON	OFF	ON	OFF

After setting above, turn the automatic ID function switch S4-2 ON.

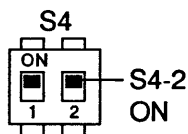

### ID speed

The ID speed is selectable via the ID speed switch S17.

S17 position	ID speed	S17 position	ID speed
0	4 wpm	8	16 wpm
1	5 wpm	9	18 wpm
2	6 wpm	A	20 wpm
3	7 wpm	B	22 wpm
4	8 wpm	C	24 wpm
5	10 wpm	D	26 wpm
6	12 wpm	E	28 wpm
7	14 wpm	F	30 wpm

Initial setting before shipping is 10 wpm.

### Manual ID function

Push the [MANUAL ID] switch to transmit the ID call sign manually.

- The ID indicator lights up in red during ID call sign transmission.

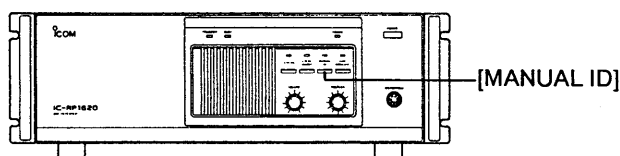

### Hang-up timer

Even when a receive signal from an accessing station temporarily disappears, the repeater delays to stop transmitting for a specified hang-up time. When a signal is received within the hang-up time, the repeater transmits continuously.

The hang-up time is selectable via the hang-up timer switch S18.

S18 position	Hang-up time	S18 position	Hang-up time
0	0 sec.	8	8 sec.
1	1 sec.	9	9 sec.
2	2 sec.	A	10 sec.
3	3 sec.	B	11 sec.
4	4 sec.	C	12 sec.
5	5 sec.	D	13 sec.
6	6 sec.	E	14 sec.
7	7 sec.	F	15 sec.

Initial setting before shipping is 1 sec.

### Time-out timer

This function inhibits one station from monopolizing the repeater.

If a station accesses the repeater beyond the specified time-out time, the repeater automatically stops for a specified repeater-stopping time period.

The time-out time is selectable via the time-out-timer switch S19.

S19 position	Time-out time	S19 position	Time-out time
0	1 min.	8	9 min.
1	2 min.	9	10 min.
2	3 min.	A	11 min.
3	4 min.	B	12 min.
4	5 min.	C	13 min.
5	6 min.	D	14 min.
6	7 min.	E	15 min.
7	8 min.	F	Unrestricted

Initial setting before shipping is 3 min.

## ■ Repeater-stopping timer

This function allows you to set the repeater-stopping time period after time out.

Repeater-stopping time is selectable via the repeater-stopping time switch S20.

S20 position	Repeater-stopping time	S20 position	Repeater-stopping time
0	0 sec.	8	30 sec.
1	1 sec.	9	40 sec.
2	2 sec.	A	50 sec.
3	3 sec.	B	1 min.
4	5 sec.	C	2 min.
5	10 sec.	D	3 min.
6	15 sec.	E	5 min.
7	20 sec.	F	10 min.

Initial setting before shipping is 5 sec.

## ■ Time-out signal

The 30S port (J6, pin 6) on the LOGIC unit is grounded 30 sec. before the time-out time. This port can be used for external equipment to provide time-out time notice, etc.

Equipment with the following specifications can be connected:

- Max. voltage: 24 V DC
- Max. current: 100 mA

If a relay or other inductive load is connected, to protect the port from surge voltage, connect a diode in parallel.

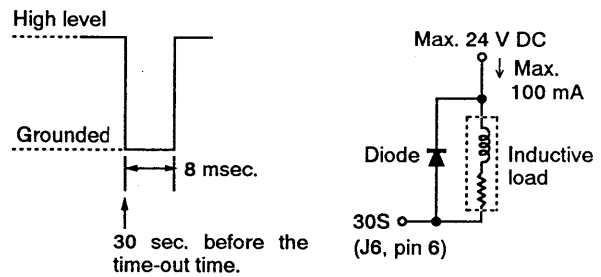

## ■ ID transmitting timing

The following charts show selectable ID transmitting patterns: types A, B and C. Each chart shows a repeater operation example.

In the following charts, timers are set at initial setting before shipping:

- Ⓐ Hang-up timer 1 sec.
- Ⓑ Time-out timer 3 min.
- Ⓒ Repeater-stopping timer 5 sec.

### Type A

1 When 1 station monopolizes the repeater for more than 3 min.

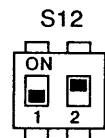
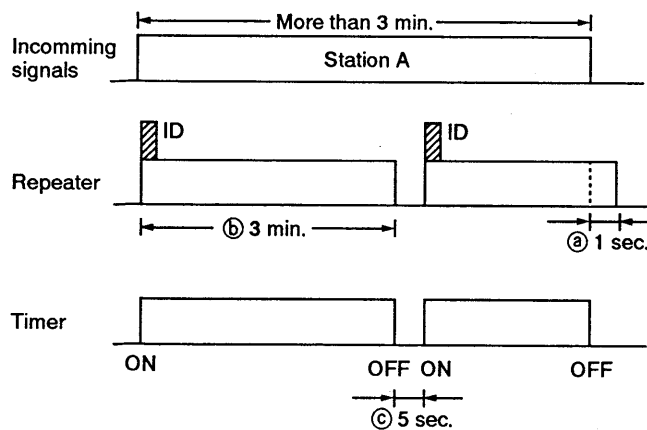

## 5 ADVANCED PRESETTINGS AND OPERATION

### Type A (continued)

- 2** When 2 stations communicate for more than 3 min. with less than 1 sec. intervals between transmissions.

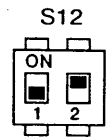
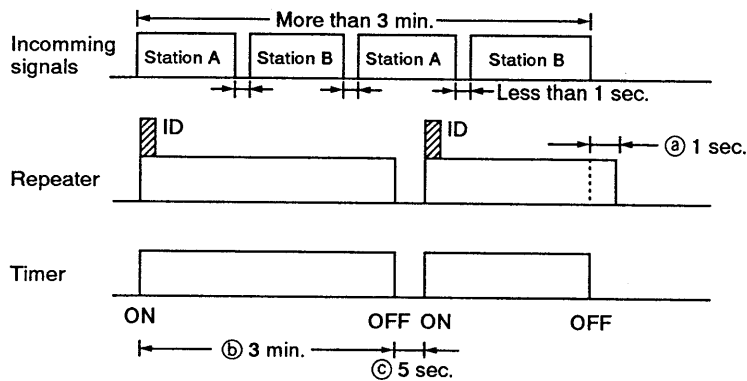

- 3** When 2 stations communicate for more than 3 min. with more than 1 sec. intervals between transmissions.

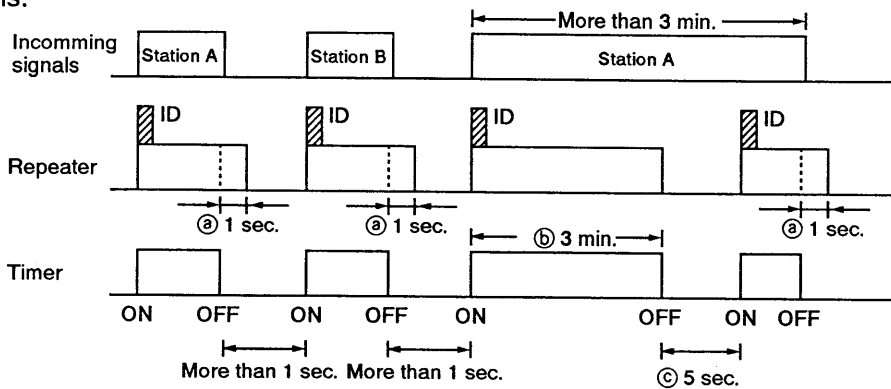

### Type B

- 1** When 2 stations communicate with less than 1 sec. intervals between transmissions.

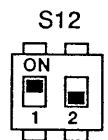
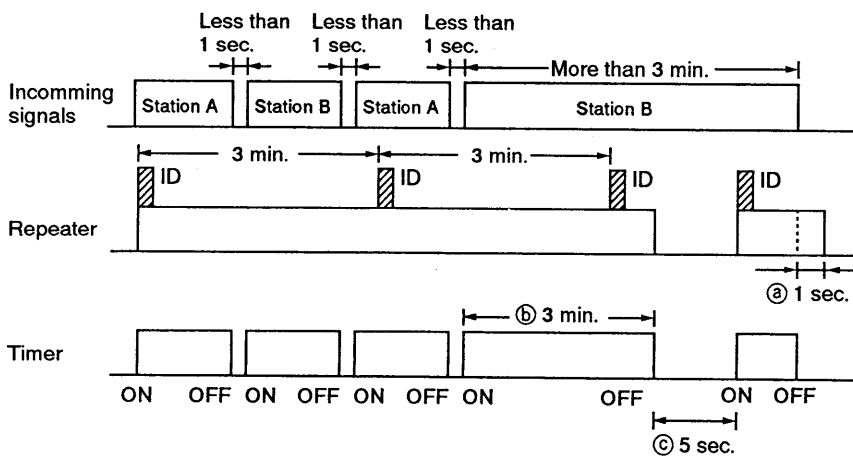

- 2** When 1 station monopolizes the repeater for more than 3 min. The repeater operates the same as Type A **1**.

- 3** When 2 stations communicate with more than 1 sec. intervals between transmissions. The repeater operates the same as Type A **3**.

Type C

- 1 When 1 station monopolizes the repeater for more than 3 min.

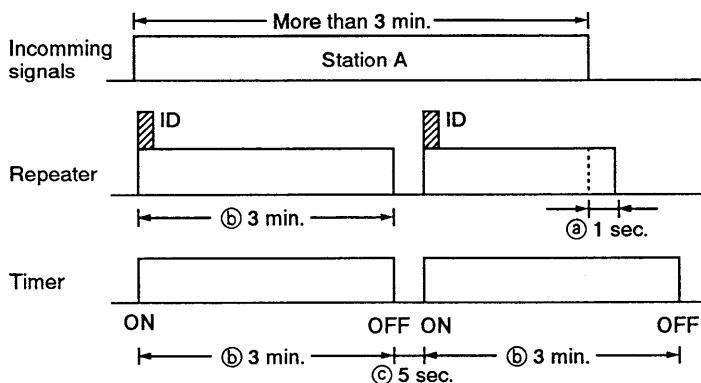
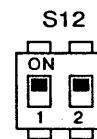

- 2 When 2 stations communicate for more than 3 min. with less than 1 sec. intervals between transmissions.

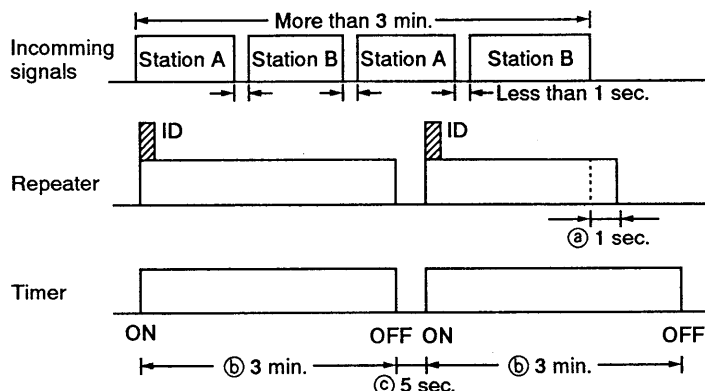

- 3 When 2 stations complete communications within 3 min., and other stations use the repeater with more than 1 sec. intervals between transmissions.

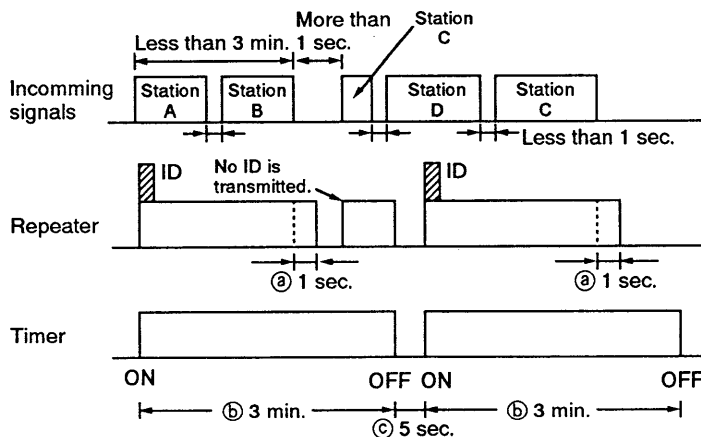

## ■ ID call sign setting

If ID call sign in Morse code is required, set as following:

- 1) Remove the bottom cover.
  - Refer to p. 15 "Disassembly" for details.
- 2) To erase a previous ID call sign, S7 and S8 to the "C" position, and then push S6.

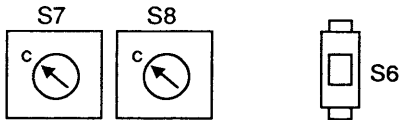

- 3) To select a desired character, select S7 and S8 according to the table at right, and then push S6.
- 4) Repeat step 3) until the ID call sign is completely written.
  - Up to 20 characters including spaces can be stored.
- 5) After step 4), select S7 and S8 to the "F" position, and then push S6.
  - ID call sign is set.

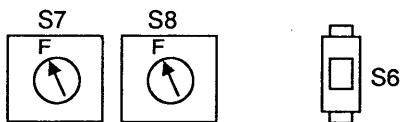

		S7 position															
		0	1	2	3	4	5	6	7	8	9	A	B	C	D	E	F
S8 position	0	0	1	2	3	4	5	6	7	8	9						
	1	A	B	C													
	2	D	E	F													
	3	G	H	I													
	4	J	K	L													
	5	M	N	O													
	6	P	Q	R													
	7	S	T	U													
	8	V	W	X													
	9	Y	Z	/													
A																	
B																*1	
C																*2	
D																	
E																	
F																*3	

\*1 Space \*2 Erase \*3 Enter

## ■ Remote control function

In some countries, you can control the repeater using DTMF codes. Ask your Icom Dealer for details, since the radio law varies according to country.

### Control signal input jack

Either the repeater receive frequency or an external receiver can be used for remote control.

- **Control on the repeater's receive frequency**  
Leave the [CONTROL INPUT] jack unconnected.
- **Control on another frequency**  
Connect an audio output jack of an external receiver to the [CONTROL INPUT] jack. Refer to p. 3 "Rear panel connections" for location.
  - Plug type : 3.5<sup>φ</sup> mini plug
  - Max. input level : 1.0 V (RMS)

### Password setting

To prevent unauthorized control, set a 4-digit password via the password switches S13-S16. "1" to "9" or "A" to "F" is selectable for each digit. Initial setting before shipping is "123A."

### Code composition

Transmit the following DTMF code within 30 sec.

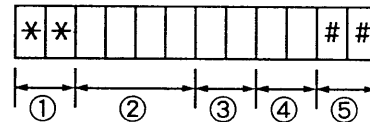

- ① Preamble
- ② Password  
If the 1st digit is "0" to "9," to prevent a password being heard, the repeater stops transmission.
- ③ Command  
Refer to p. 14 "Command and data" for details.
- ④ Data  
Data length varies according to command. Refer to p. 14 "Command and data" for details.
- ⑤ Postamble  
Transmission resumes when "##" is received.



**Command and data**

The following controls are possible.

Command	Data	Description	Initial	Ref.
00	0	Turns the CTCSS decoder OFF.	ON	p. 6
	1	Turns the CTCSS decoder ON.		
01	0	Turns the CTCSS encoder OFF.	OFF	p. 8
	1	Turns the CTCSS encoder ON.		
02	01 – 10, 12 – 38	Selects a CTCSS encoder frequency. Refer to p. 8 "CTCSS frequency table" and select a corresponding tone number as data.	Dip S11	p. 8
03	01 – 38	Selects a CTCSS decoder frequency. Refer to p. 8 "CTCSS frequency table" and select a corresponding tone number as data.	Dip S3	p. 8
10	0	Turns the local inhibit function OFF.	OFF	p. 6
	1	Turns the local inhibit function ON.		
20	1	Activates manual ID function.	—	p. 9
21	0	Turns the automatic ID function OFF.	ON* <sup>3</sup>	p. 9
	1	Turns the automatic ID function ON.		
30	0	Turns the USER1 port OFF. (High level)	LOGIC unit (J6, pin 4)* <sup>1</sup>	OFF
	1	Turns the USER1 port ON. (Grounded)		
31	0	Turns the USER2 port OFF. (High level)	LOGIC unit (J6, pin 3)* <sup>1</sup>	OFF
	1	Turns the USER2 port ON. (Grounded)		
32	0	Turns the USER0 port OFF. (High level)	LOGIC unit (J6, pin 5)* <sup>1</sup>	OFF
	1	Turns the USER0 port ON. (Grounded)		
40	01 – 16	Selects the time-out time.	Dip S19	pgs. 9, 19
41	01 – 16	Selects the hang-up time.	Dip S18	pgs. 9, 19
42	01 – 16	Selects the repeater-stopping time.	Dip S20	pgs. 10, 19
43	01 – 16	Selects the ID speed.	Dip S17	pgs. 9, 19
A0	01 – 07	Fine tuning of the operating frequency. –1 to –7 positions.	±0	—
	11 – 17	Fine tuning of the operating frequency. +1 to +7 positions.		
D9	9	Resets the CPU.* <sup>2</sup>	—	p. 15

\*<sup>1</sup> The USER1, USER2 and USER0 ports can be used for external equipment control.

Recommended circuit is the same as the 30S port. Refer to p. 10 "Time-out signal" for required circuit.

\*<sup>2</sup> Even when the CPU is reset, the following settings are not reset:  
 – Fine tuning of the operating frequency  
 – Automatic ID function ON/OFF

\*<sup>3</sup> To activate the automatic ID function, turn the automatic ID function switch S4-2 ON.

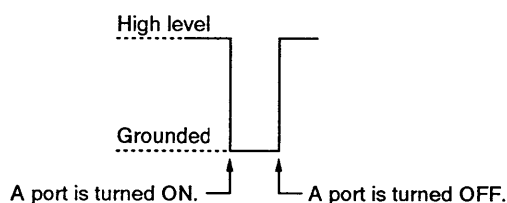

# 6 MAINTENANCE

## Disassembly

**⚠ WARNING: HIGH VOLTAGE!** DISCONNECT the AC power cable from the repeater before performing any internal work. Use a DC power supply during dip switch selection.

- 1) Turn the [POWER] switch OFF.
- 2) Disconnect the AC power cable.
- 3) Remove the 3 screws from each side of the rack mounting handles and remove the rack mounting handles.
- 4) Remove the 6 screws from the side panels.
- 5) Remove the 6 screws on the top panel cover and remove the top cover.
- 6) Remove the 6 screws on the bottom cover and remove the bottom cover.

## RAM backup battery

**⚠ WARNING:** If a lithium backup battery is incorrectly replaced, an explosion may occur. Replace with the BR2032-1HF or equivalent type.

The backup battery should be replaced by an authorized Icom Dealer or Service Center.

The repeater has a lithium backup battery for retaining programmed contents in a RAM IC chip including ID call sign information.

The usual life of the backup battery is approx. 5 years. When the battery is exhausted, the repeater operates, but cannot retain ID call sign settings.

## Cleaning

If the repeater becomes dusty or dirty, wipe it clean with a dry, soft cloth.

**CAUTION:** AVOID the use of strong chemical agents such as thinner, benzine or alcohol. They may damage the repeater surfaces.

## Fuse replacement

**⚠ WARNING: NEVER** use not-rated fuses. Not-rated fuses could cause a fire.

If a fuse blows, find the source of the problem. Replace the damaged fuse with a new, rated fuse.

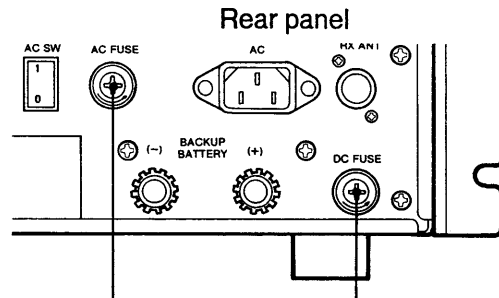

AC fuse holder  
5.2<sup>φ</sup> × 20 mm

DC fuse holder  
6.4<sup>φ</sup> × 30 mm, 20 A

— U.S.A. version:

5 A time-lag type

— Europe version:

2.5 A time-lag type

## CPU resetting

The repeater may operate erroneously. This may be caused externally by static electricity or other factors. If this problem occurs, turn the power OFF. Wait a few seconds, then turn the power ON again.

CPU resetting can be performed remotely. Transmit the following DTMF code within 30 sec. Refer to p. 13 "Remote control function" for details.

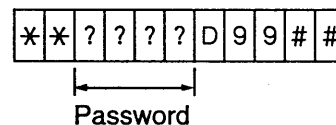

**NOTE:** CPU resetting initializes settings to those on the chart on p. 14 "Command and data." However, the following settings are NOT initialized:

- Fine tuning of the operating frequency
- Automatic ID function ON/OFF

## ■ Troubleshooting

The following chart is designed to help you correct problems which are not equipment malfunctions.

If you cannot locate the cause of a problem or solve it through the use of this chart, contact your Icom Dealer or Service Center.

Problem	Possible case	Solution	Ref.
Power does not turn ON when the [POWER] switch is pushed IN.	<ul style="list-style-type: none"> <li>• AC power cable or DC power cable is improperly connected.</li> <li>• Fuse is blown.</li> <li>• Battery is exhausted.</li> <li>• The [AC SW] switch on the rear panel is in the "O" position.</li> </ul>	<ul style="list-style-type: none"> <li>• Connect the power cable correctly.</li> <li>• Check for the cause, then replace the fuse. The repeater has an AC fuse and a DC fuse.</li> <li>• Check the battery voltage while the [POWER] switch is pushed IN. If required, charge the battery and then push the [DC RESET] switch on the rear panel.</li> <li>• For AC power operation, turn the [AC SW] switch to the "I" position.</li> </ul>	<p>p. 5</p> <p>p. 15</p> <p>p. 6</p> <p>p. 6</p>
No sound comes from the speaker.	<ul style="list-style-type: none"> <li>• Volume level is too low.</li> <li>• The squelch is closed.</li> <li>• Wrong receive frequency or PLL reference frequency is selected.</li> </ul>	<ul style="list-style-type: none"> <li>• Rotate the [VOLUME] control clockwise.</li> <li>• Rotate the [SQUELCH] control counter-clockwise.</li> <li>• Select the correct receive frequency or PLL reference frequency.</li> </ul>	<p>p. 6</p> <p>p. 6</p> <p>p. 7</p>
Sensitivity is low.	<ul style="list-style-type: none"> <li>• The antenna is not connected properly.</li> <li>• The coaxial cable is cut or shorted.</li> <li>• Selected receive frequency is outside the duplexer bandwidth.</li> </ul>	<ul style="list-style-type: none"> <li>• Reconnect the antenna properly.</li> <li>• Check the coaxial cable and correct any improper conditions.</li> <li>• Adjust the duplexer or use a suitable duplexer for the receive frequency.</li> </ul>	<p>p. 4</p> <p>p. 4</p> <p>p. 4</p>
Received signal is not repeated.	<ul style="list-style-type: none"> <li>• The the [LOCAL INHIBIT] switch is pushed IN.</li> <li>• Selected CTCSS decoder frequency is wrong.</li> <li>• The [SQUELCH] control is rotated too far clockwise.</li> </ul>	<ul style="list-style-type: none"> <li>• Push the [LOCAL INHIBIT] switch OUT.</li> <li>• Select the correct CTCSS decoder frequency.</li> <li>• Rotate the [SQUELCH] control counter-clockwise to set the weakest receive signal strength that you wish to repeat.</li> </ul>	<p>p. 6</p> <p>p. 8</p> <p>p. 6</p>
No output power or the output power is too low.	<ul style="list-style-type: none"> <li>• Selected transmit frequency or PLL reference frequency is wrong.</li> <li>• Selected transmit frequency is outside the duplexer bandwidth.</li> <li>• The antenna is not connected properly.</li> </ul>	<ul style="list-style-type: none"> <li>• Select the correct transmit frequency or PLL reference frequency.</li> <li>• Adjust the duplexer or use a suitable duplexer for the transmit frequency.</li> <li>• Check the coaxial cable and correct any improper conditions.</li> </ul>	<p>p. 7</p> <p>p. 4</p> <p>p. 4</p>
ID call sign is not sent out.	<ul style="list-style-type: none"> <li>• The ID call sign switch is turned OFF.</li> <li>• Lithium backup battery is exhausted.</li> </ul>	<ul style="list-style-type: none"> <li>• Turn the automatic ID function switch S4-2 on the LOGIC-A unit ON.</li> <li>• Lithium backup battery replacement is required. Ask your Icom Dealer.</li> </ul>	<p>p. 9</p> <p>p. 15</p>
Hand microphone audio is not modulated.	<ul style="list-style-type: none"> <li>• The [MICROPHONE] connector has a poor contact.</li> </ul>	<ul style="list-style-type: none"> <li>• Check the connector pins.</li> </ul>	<p>p. 5</p>

### Top view

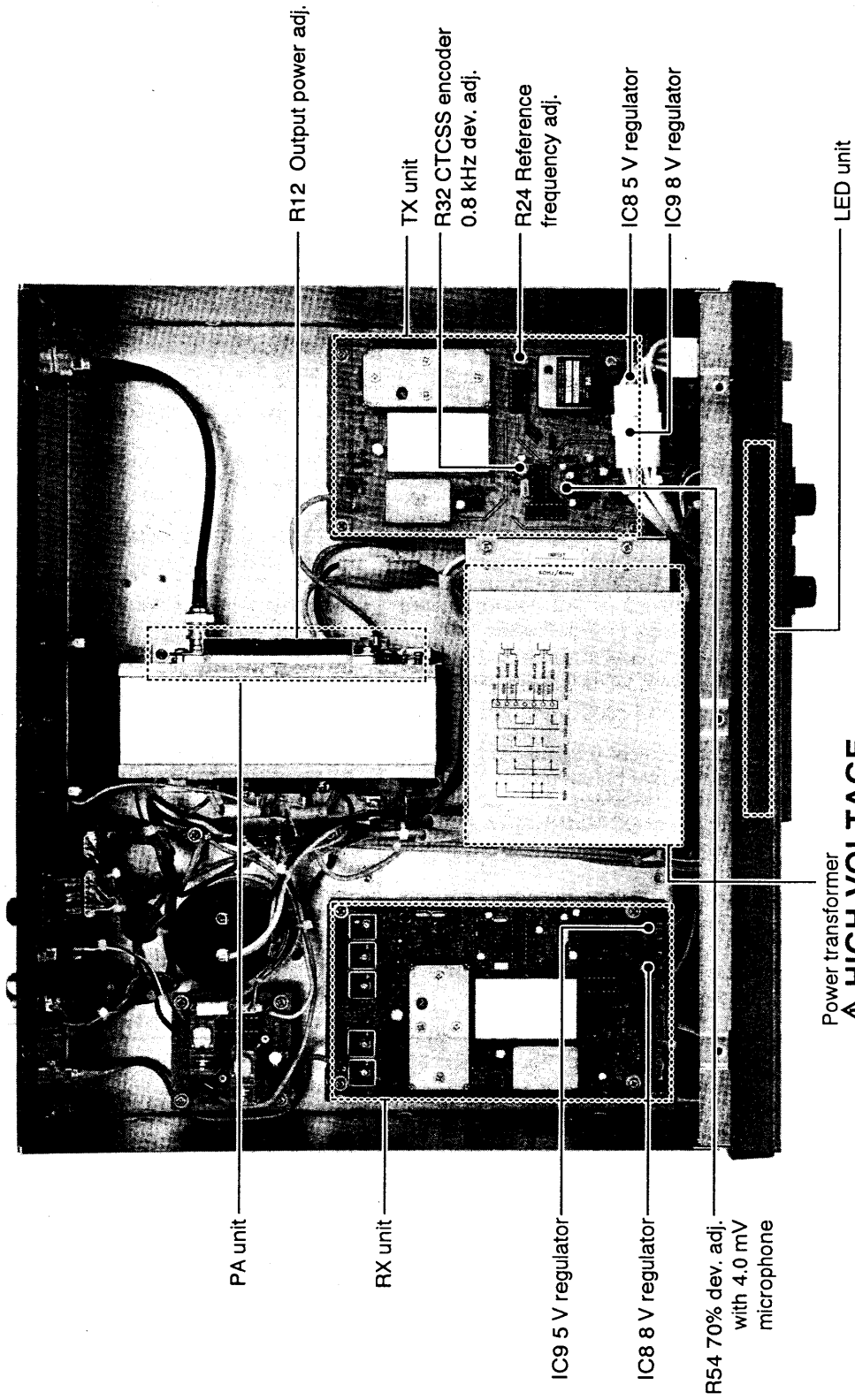

**⚠ HIGH VOLTAGE**  
**NEVER disassemble.**

**Bottom view**

J6 30S and USER1 –  
USER0 ports

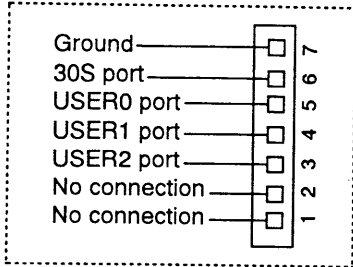

Refer to pgs. 10, 14.

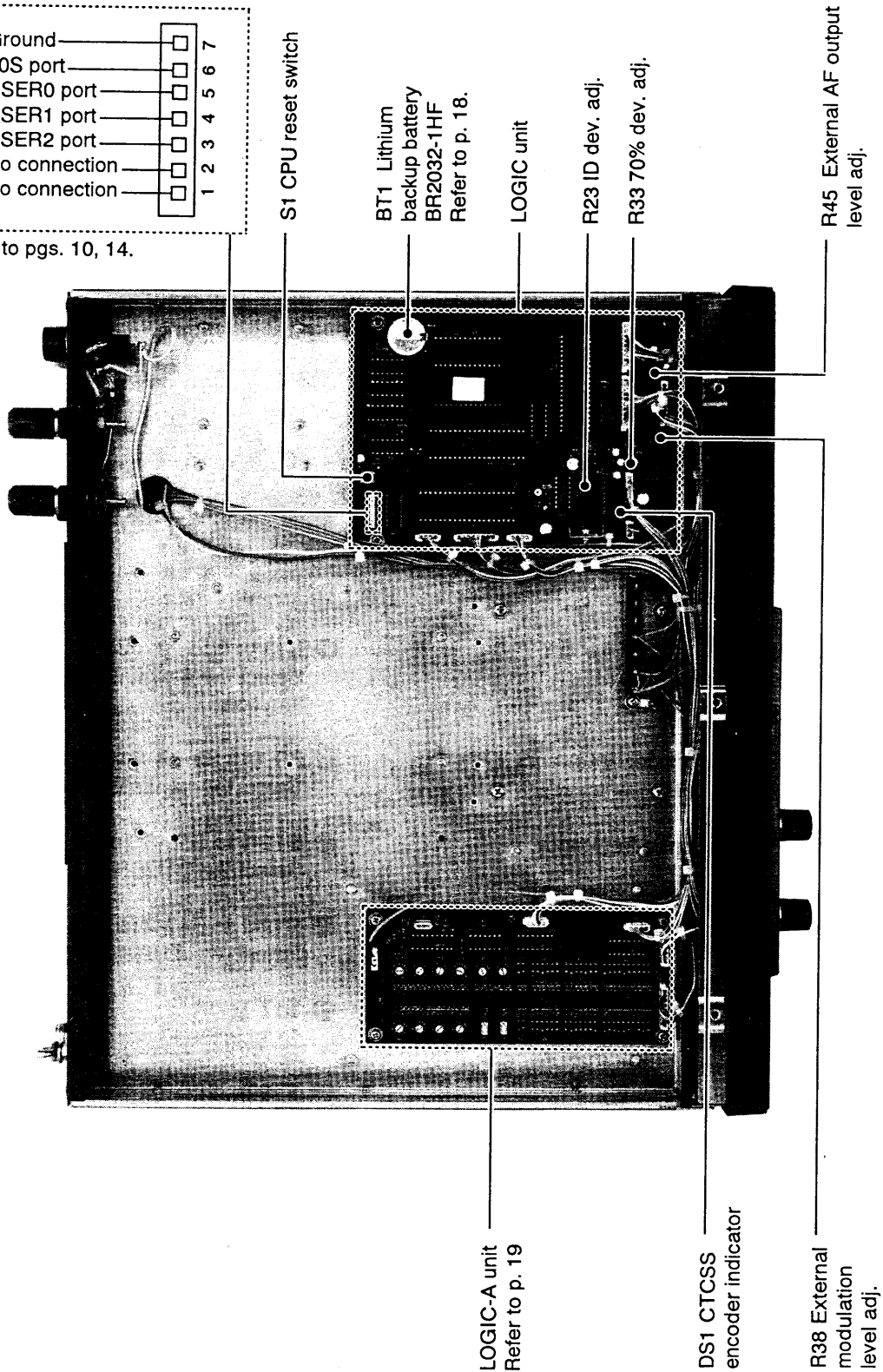

LOGIC-A unit  
Refer to p. 19

DS1 CTCSS  
encoder indicator

R38 External  
modulation  
level adj.

S1 CPU reset switch

BT1 Lithium  
backup battery  
BR2032-1HF  
Refer to p. 18.

LOGIC unit

R23 ID dev. adj.

R33 70% dev. adj.

R45 External AF output  
level adj.

## LOGIC-A unit

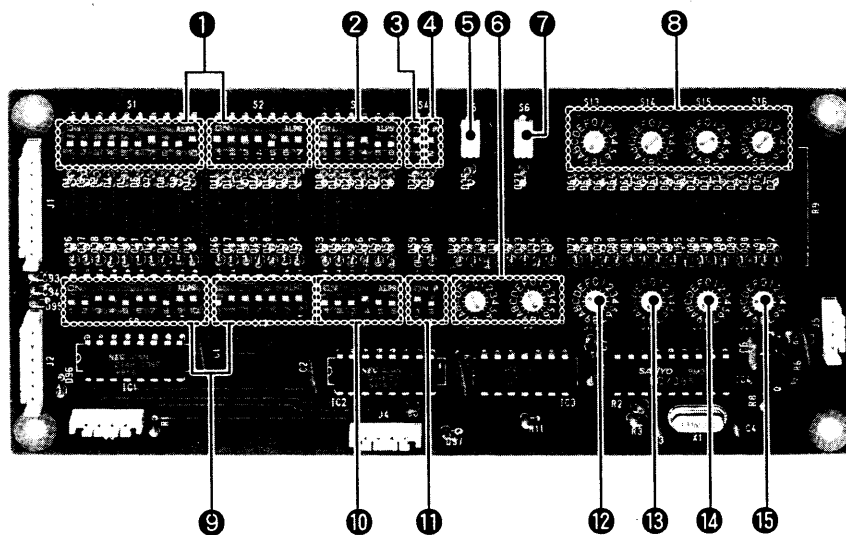

- |  |   |
|--|---|
| <p><b>❶ S1-1 to S1-10, S2-1 to S2-7</b> (p. 7)<br/>Select the receive frequency.</p> <p><b>❷ S3-1 to S3-6</b> (p. 8)<br/>Select the CTCSS decoder frequency.</p> <p><b>❸ S4-1</b> (p. 7)<br/>Selects the PLL reference frequency.</p> <p><b>❹ S4-2</b> (p. 9)<br/>Turns the automatic ID function ON and OFF.</p> <p><b>❺ S5</b> (p. 8)<br/>Turns the CTCSS encoder ON and OFF.<br/>• The CTCSS encoder indicator DS1 on the LOGIC unit lights up when the CTCSS encoder is ON.</p> <p><b>❻ S7 and S8</b> (p. 13)<br/>Select a character for ID call sign writing.</p> <p><b>❼ S6</b> (p. 13)<br/>Writes the ID call sign.</p> | <p><b>❽ S13 to S16</b> (p. 13)<br/>Select the 4-digit password for the remote control function.</p> <p><b>❾ S9-1 to S9-10, S10-1 to S10-7</b> (p. 7)<br/>Select the transmit frequency.</p> <p><b>❿ S11-1 to S11-6</b> (p. 8)<br/>Select the CTCSS encoder frequency. (p. 8)</p> <p><b>⓫ S12-1 to S12-2</b> (p. 9)<br/>Select the ID transmit pattern.</p> <p><b>⓬ S17</b> (p. 9)<br/>Selects the ID speed.</p> <p><b>⓭ S18</b> (p. 9)<br/>Selects the hang-up time.</p> <p><b>⓮ S19</b> (p. 9)<br/>Selects the time-out time.</p> <p><b>⓯ S20</b> (p. 10)<br/>Selects the repeater stopping time after time out.</p> |
|--|---|

## ■ General

- Frequency coverage : 150 – 174 MHz\*  
\*Permitted frequency range differs according to countries.
- Mode : FM 16K0F3E  
FM 8K50F3E (narrow version)
- Initial tuning step : 5 or 12.5 kHz (selectable)
- Antenna impedance : 50 Ω
- AC power supply requirement : U.S.A. version 117 V AC ±10%, 50/60 Hz  
Europe version 230 V AC ±10%, 50/60 Hz
- AC power consumption : 240 VA
- DC power supply requirement : 13.8 V DC ±15%
- Current drain (at 13.8 V DC) : Transmit 15 A  
Receive Squelched 1.0 A  
Max. audio 1.2 A
- Usable temperature range : –10°C to +60°C
- Frequency stability : ± 0.0001%
- Dimensions : 425(W) × 149(H) × 368(D) mm  
16.7(W) × 5.9(H) × 14.5(D) in  
(projections not included)
- Weight : 17.0 kg; 37.5 lb

## ■ Transmitter

- Output power : 50 W
- Modulation system : Variable reactance frequency modulation
- Max. frequency deviation : ±5.0 kHz  
±2.5 kHz (narrow version)
- Spurious emissions : –70 dB
- Microphone impedance : 600 Ω

## ■ Receiver

- Receive system : Double-conversion superheterodyne
- Intermediate frequencies : 1st 21.8 MHz 2nd 455 kHz
- Sensitivity : 0.5 μV for 12 dB SINAD
- Tight squelch sensitivity : 1.0 μV
- Adjacent channel selectivity : –70 dB  
–60 dB (narrow version)
- Spurious rejection : –70 dB
- Audio output power : 1.7 W with an 8 Ω load
- Audio output impedance : 8 Ω

All stated specifications are subject to change without notice or obligation.

**Count on us!**

